

Chapter 13 - Finish Framing

Contents

Chapter 13 - Finish Framing	13-1
Timing & Prerequisites	13-2
Remove Bottom Plates in Doorways.....	13-2
Post LVLs and Girder Trusses.....	13-2
Install Framing for Stairway Ceiling.....	13-4
Install Attic Access.....	13-4
Blocking.....	13-6
Install Kitchen Cabinet Blocking.....	13-6
Install Bathroom Blocking	13-6
Install Handrail Blocking.....	13-6
Drywall Stops & Blocking.....	13-7
Build Basement Shelves.....	13-8
Quality Assurance Checklist.....	13-10

Components	
Basement Shelving Blocking	Attic Access Drywall Stops and Deadwood Blocking

Timing & Prerequisites

- Although this phase of the project cannot be completed until the framing is complete, some of the activities will be performed during the framing activities.
 - The bottom plates which extend through doorways should be removed as soon as possible.
 - The attic accesses will be installed after the roof framing.
- The House/Project Lead will work with the Construction Superintendent to coordinate these volunteer activities.

Materials Needed	
Blocking	Basement Shelving
2x4s 2x8s 16d Sinker Nails	2x4s 1/2" OSB 16d Sinker Nails 8d Sinker Nails
Drywall Stops	Attic Access
Drywall Stops	2x4s 1/2" OSB 16d Sinker Nails 8d Sinker Nails

Remove Bottom Plates in Doorways

1. Toe-nail through the bottom plate between the king and jack studs on each side of the door into the flooring with a 16d sinker; four (4) 16d sinkers per door.
2. Use a reciprocating saw to cut the bottom plate which extends across the bottom of the doorways. Cut down through the plate on both sides of the doorway.
3. Use a hammer to tap the 2x4 out of the door.

Post LVLs and Girder Trusses

A set of jack studs must be installed under each end of a LVL or girder truss. The width of the set of jack studs must be equal to width of the LVL or girder truss above.

Add jack studs to support any girders, beams or headers.

- Nail together two (2) precut studs with 10d sinkers; 2 nails spaced approximately 12” apart; spread across the face of the studs. Sandwich on additional precut studs as needed to create the correct width.
- Toe-nail the set of studs in place with 16d sinkers.

Additional Framing

Install Framing for Stairway Ceiling

If the house model calls for a stairway ceiling, the framing will be added after the stairs are installed.

1. The stairway ceiling will be framed with a 2x4 header to hold the top of the stairway ceiling and 2x4 ceiling joists running from the 2x4 header at the top of stairs to a header at the bottom of the stairs. The headers must support the ceiling joists at a minimum height 6' 9".
2. Install the header at the top of the stairs.
 - Cut a 2x4 long enough to extend across the top of the stairway.
 - Position the 2x4 header on top of the double top plates of the walls on either side of the stairs. The 2x4 header should be placed even with the top of the stairs.
 - Nail the 2x4 header in with 16d sinkers.
3. If the house plans call for a header at the bottom of the stairs, build and install it as specified in the plan.
4. Install ceiling support rails.
 - Snap a chalk line on the studs along the side of the stairway, starting at the front edge of the header just installed; extending down to the bottom corner of the header at the bottom of the stairs.
 - Measure this line and cut three 2x4s to that length.
 - Cut one end of each 2x4 with an angle to fit under the 2x4 header just installed and the other end with an angle to fit at the bottom corner of the header at the bottom of the stairs. To determine the angles needed, hold one of the 2x4 flush to the bottom of the chalk line. Lay a scrap piece of 2x4 across the face of the 2x4 and flush to the top header. Draw a line on the cut 2x4 even with the bottom of the scrap 2x4. Repeat this procedure at the bottom header.
 - Nail 2 rails to the sides of the stair wall. Nail through the rails into the studs with 16d nails.
 - Nail the 3rd rail down the center of the stairway. Nail through the top into the 2x4 header and the bottom into the header.

Install Attic Access

1. Locate the position of the attic access on the prints and confirm the location with the Superintendent. The access must be installed between two roof trusses which are 24" o.c. and there will be 32" of clearance above the opening.
2. Mark the location on the horizontal members of the truss. The opening should be 22 ½" by 32".

3. Cut 2x4 blocks to go between the horizontal members of the trusses. This will be 22 ½”.
4. Nail the blocks in place with 16d sinkers. Nail each corner in with 2 nails.
5. Cut pieces of 1/2” OSB to fit inside the access opening; 13” above the truss which means you will need 2 pieces 22 ½” by 18” and 2 pieces 31” by 16 ½”.
6. Nail these pieces into the opening flush with the bottom of the truss with 8d sinkers.

Blocking

Critical Issues

- **Blocking must be installed flush to the studs to prevent bumps in the drywall.**

Blocking is needed in various places to provide an anchor point for hanging things like cabinets and handrails.

1. The blocking is installed before the drywall and flush to the studs with the wide side of the material facing into the room.
2. Blocking can be cut from 2x4s, 2x6s or 2x8s, depending on how much of an anchor is needed and how much room is available.
3. Blocks are cut from 2x material to go between the studs. Usually these will be 14 ½”.
4. Nail the blocks in place with 16d sinkers. Nail 2 nails through the studs into each end of the blocking if possible. Otherwise, toe-nail with 8d sinkers into each end.

Install Kitchen Cabinet Blocking

1. Locate the position of the kitchen cabinets on the prints and mark their location on the floor.
2. Measure up from the floor and make a mark at 84” on the studs in the wall where the cabinets will go.
3. Cut 2x4 blocks to fit between the studs.
4. Install a 2x4 block at each mark; positioned on edge (3 ½” side facing out); and with the center of the block aligned with the marks.

Install Bathroom Blocking

1. Install blocking for the grab bars.
 - a. Discuss the placement of ADA blocking needed with the Superintendent.
 - b. Cut 2x4 blocks needed.
 - c. Install 2x4 blocking where directed.

Install Handrail Blocking

1. Cut and install 2x8 blocks between the studs at various locations.
2. Install 2x8 blocks above several stairway tread nosing running parallel to the plane of the steps. (See figure 13.1)
3. Install the block with the top of the blocking 34” above the step.
4. Install blocks above the tread of the first, middle and last step.
5. Place marks on the treads below the handrail blocking to be used when installing the handrail brackets later.

- Cut a 2x8 block.
- Install the 2x8 block at the base of the staircase to provide an anchor point for the baseboard trim. Install this block flush to the bottom plate in the cavity where the staircase ends.

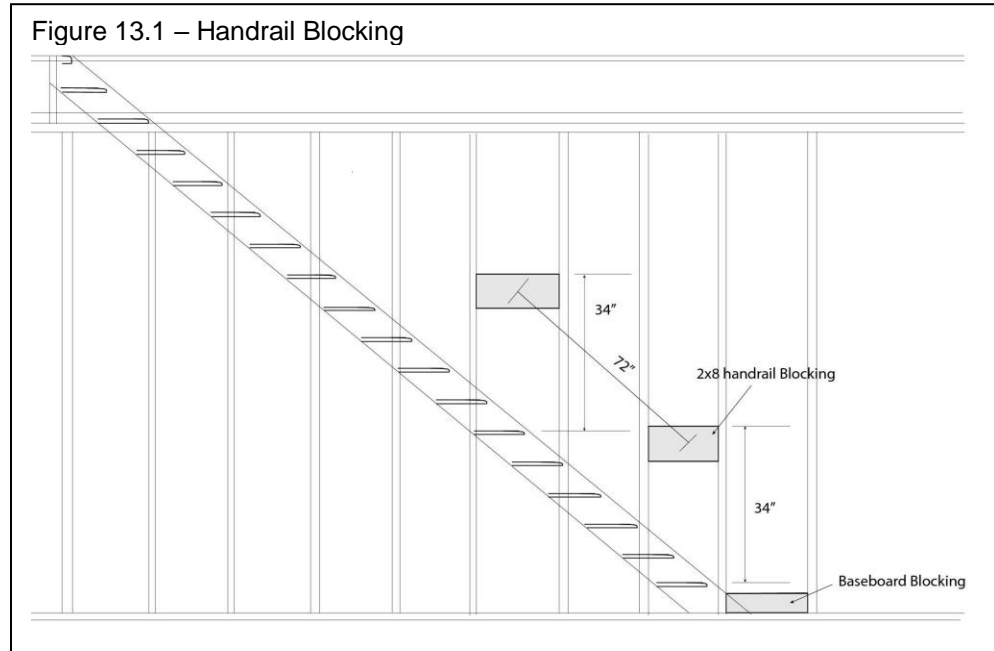

Drywall Stops & Blocking

Install drywall stops along vertical framing edges and dead-wood blocking along horizontal framing edges to provide support for the drywall.

Drywall Stops (Vertical)

Install drywall stops along the vertical end stud of a wall panel which intersects another panel forming an inside corner. (See Figure 13.2). Install a drywall stop every 10" along the end. Do not install stops if there is a wall stud within 3" of the corner.

Install the stops with the large support edge behind the area where the drywall will rest. Install the stops with 1" roofing nails.

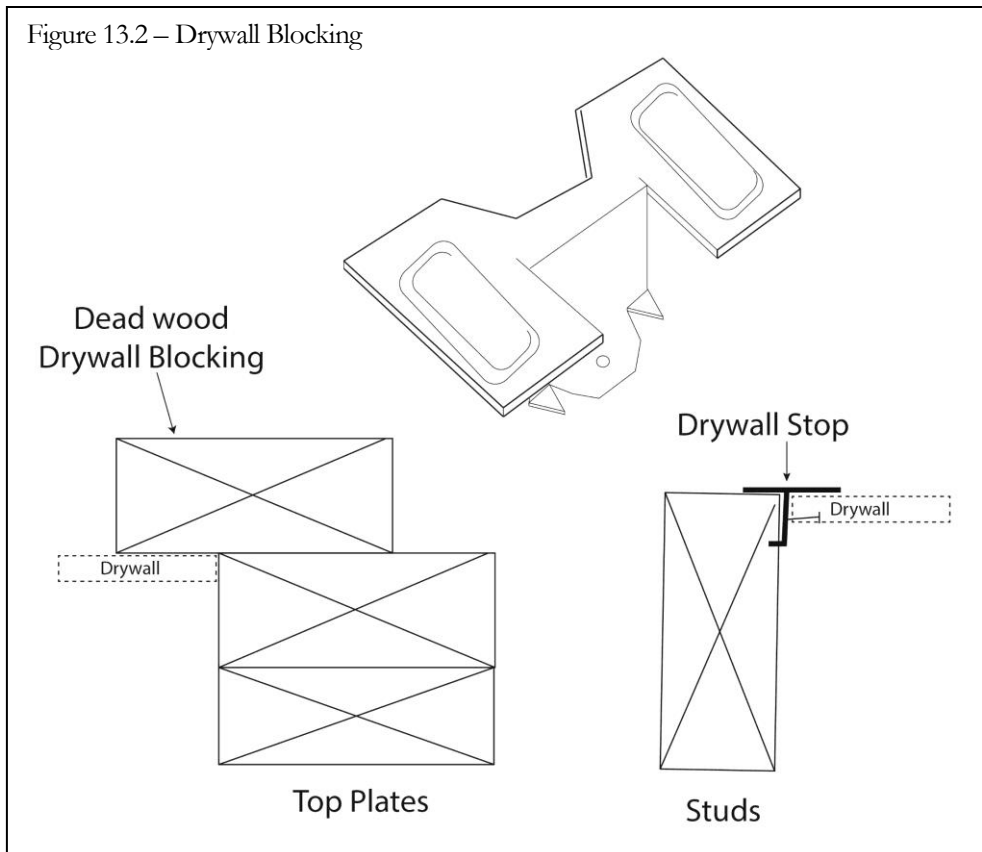

Drywall Blocking (Horizontal)

For interior walls, which run parallel to the trusses above and do not have a truss within 6" of the edge of the wall, install 2x4 blocking horizontally across the top of the wall.

Cut blocks of 2x6s. Place the 2x6 on top of the second top plate of the wall with 1" of the 2x6 hanging over the edge. Nail the block in place with 10d sinker nails. A palm nailer can make this job easier.

Build Basement Shelves

Build shelving in the basement for storage. (See Figure 13.3).

Note - Build the shelving unit in the basement; it will not fit down the stairs.

1. Cut 2x4 supports for the 2 shelves:
 - a. Eight (8) 2x4s – 21" (4 for end shelf supports and 4 for center shelf blocking)
 - b. Four (4) 2x4s – 96" (front and back shelf supports)
2. Cut 1/2" OSB shelving.
 - a. Two (2) 1/2" OSB – 24" x 96"

3. Assemble the 2 shelves. Nail the 2x4 structure together using 16d sinkers; 2 nails into each joint. Attach the ½" OSB to the 2x4 structure with 8d sinkers; 1 nail every 8" around the perimeter.
4. Cut 2x4 legs.
 - a. Two (2) 2x4s – 48" (Front Legs).
 - b. Five (5) 2x4s – (Back Legs) – 93". Field verify the sill height
5. Assemble the shelving unit.
 - a. Nail the two (2) 2x4s for each of the back legs together in an "L". Keep the board flush and the top and bottom and along the back edge.
 - b. Hold the 3 back legs on the wall where the shelving will be installed. Using a level, mark a level line across the 3 legs at an average of 24" above the floor.
 - c. Attach the back legs to the bottom shelf. Keep the top of the shelf even with the line made above. Nail the legs on with 16d sinkers; 2 nails into each shelf.
 - d. Attach the back legs to the top shelf. Position the shelf 24" above the bottom shelf. Nail the legs to the shelf with 16d sinkers; 2 nails into each shelf.
 - e. Position the shelving against the wall where it will be installed. Hold each shelf level and install the front legs. Nail the legs to the shelves with 16d sinkers.
6. Anchor the shelves to the wall sill with two (2) 16d nails through each of the three (3) 2x4 back supports.

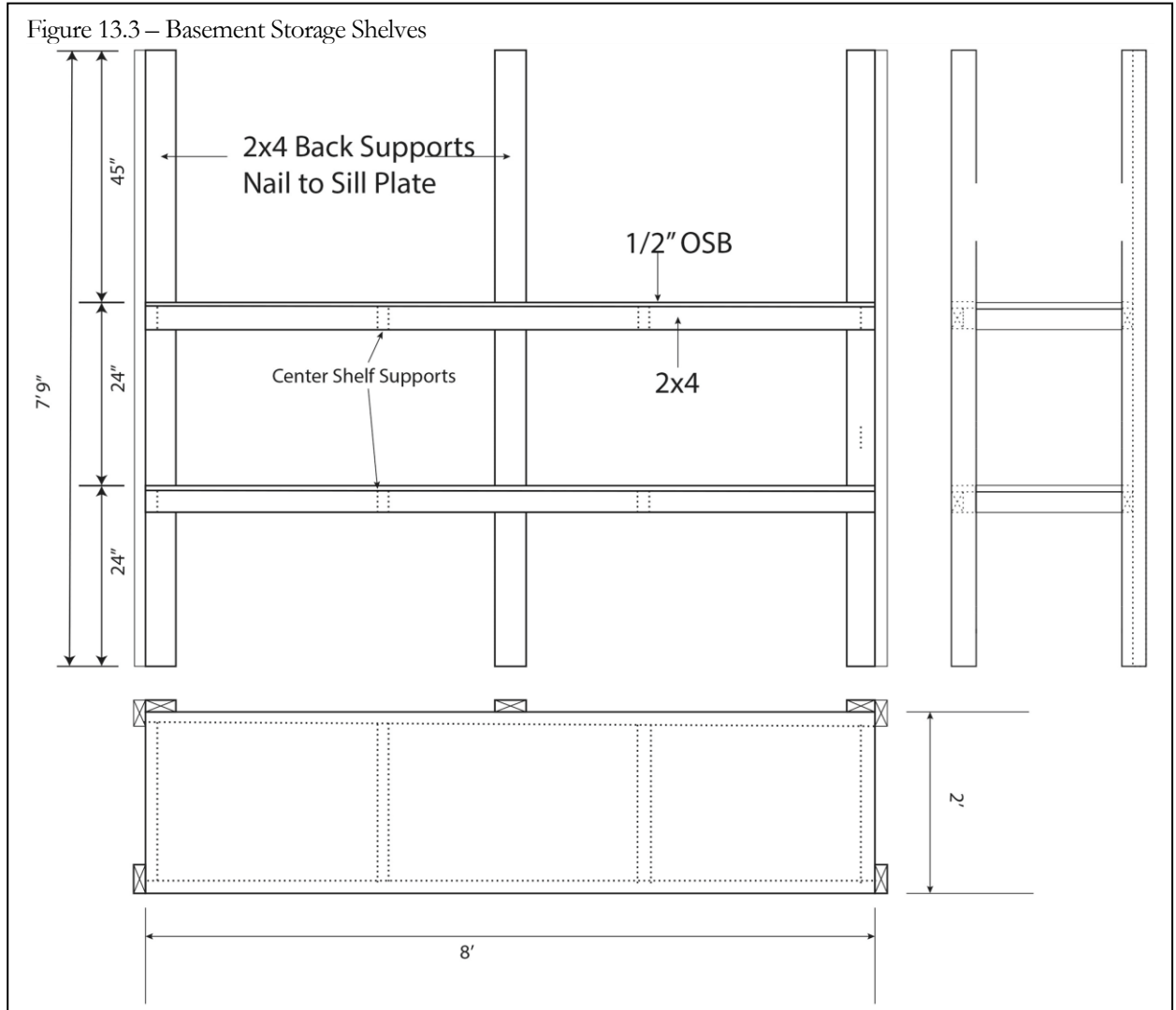

Quality Assurance Checklist

- Ensure the strong-backs are plumb and secure them to the floor trusses.
- Ensure the range hood header and framing are complete.
- Ensure the floor trusses; studs; and roof trusses stack from bottom to top.
- Ensure all LVLS and girder trusses are fully posted with double studs to foundation as required.
- Ensure wind bracing is installed to support the gable end trusses.
- Ensure one hurricane tie is installed at each end of each roof truss and holes are filled with hanger nails.
- Ensure drywall stops are installed on 2x4 studs in corners of each room and closet.
- Ensure the stairs are securely installed.
- Verify the stairway ceilings are installed with a 6' 9" clearance.
- Ensure all cabinet & ADA blocking is complete.
- Ensure there are studs that will align with the bathtub flanges.

- Check the height of blocking for cabinets and handrails.
- Take pictures of completed items.
- Ensure work site is clean and materials are properly stored before proceeding.
- Perform a final check with the “Framing Checklist” found in Site Docs.

Cabinet Blocking Height	84” to center of blocking
Handrail Blocking Height	32” to center from blocking
Attic Access Opening	22 ½” x 32”
Clearance above Attic Access	32”